



RATMO
GRUPE SISMO

Tél: 04.50.36.81.18 Fa: 04.50.36.97.49 www.ratmo.com

HEIDENHAIN



**Functional
Safety**

Provisional
Product Information

ECN 1123

EQN 1135

Rotary Encoders with
EnDat 2.2 for
Safety-Related Applications

November 2007

ECN 1123/EQN 1135 Series

Rotary encoders for safety-related applications

- With integral bearing
- Mounted stator coupling
- Installation diameter 45 mm
- Blind hollow shaft

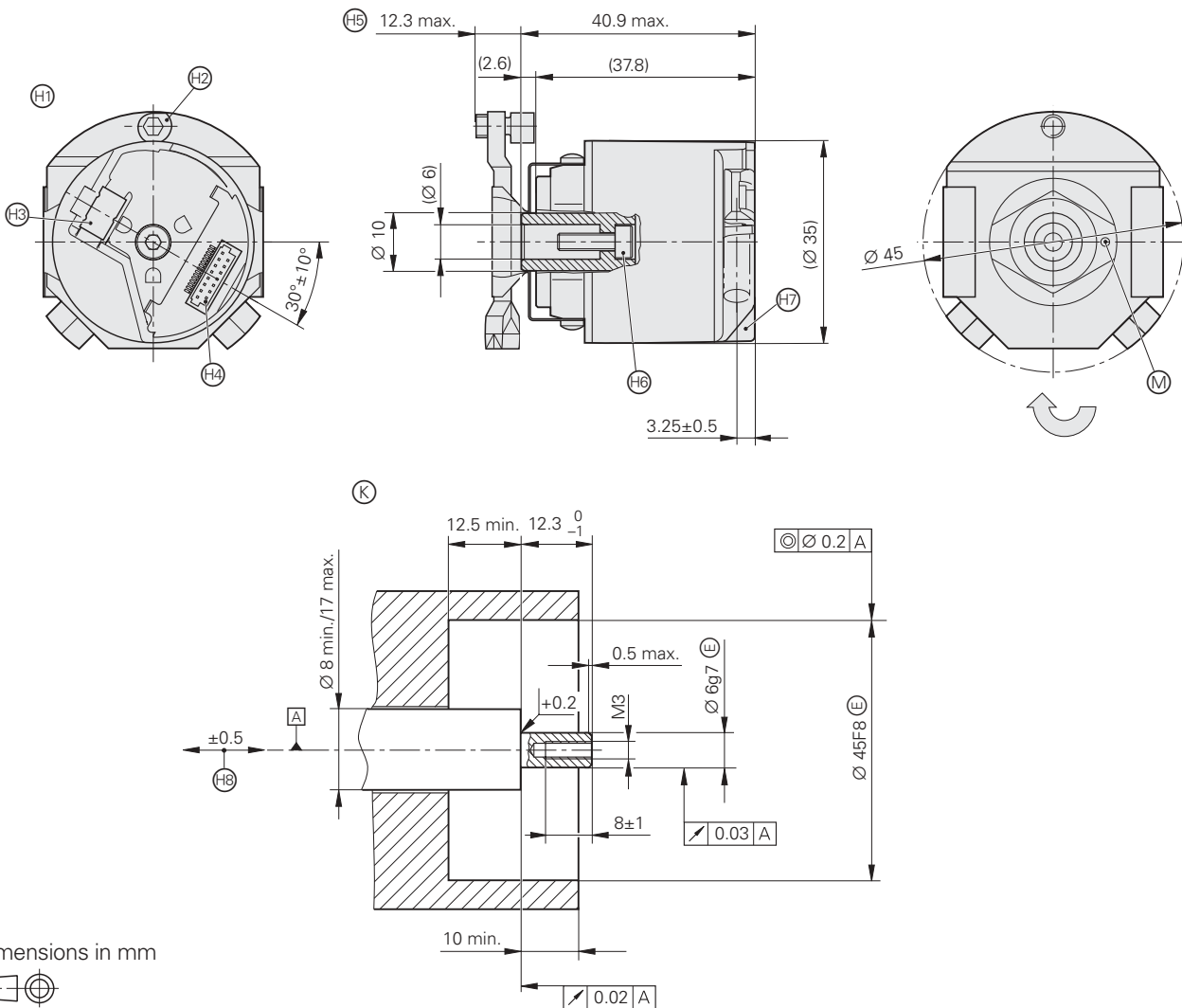

Dimensions in mm

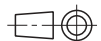

Tolerancing ISO 8015

ISO 2768 - m H

< 6 mm: ±0.2 mm

ⓐ = Bearing

Ⓚ = Required mating dimensions

Ⓜ = Measuring point for operating temperature

Ⓢ = Encoder shown without cover

Ⓣ = To fasten the ring coupling, turn the eccentric screw (M4, width A/F 3) to the right by approx. 90°. Max. tightening torque: 2±0.1 Nm

Ⓤ = Cable outlet for cables with crimp sleeve Ø 4.3±0.3 - 7 long

Ⓦ = Plug connector, 15-pin

Ⓨ = Variable depending on the coupling

Ⓩ = Screw ISO 4762, width A/F 2.5, with patch coating. Tightening torque 1.2±0.1 Nm

ECN: M3 x 10

EQN: M3 x 22

Ⓡ = Removable cover

Ⓣ = Compensation of mounting tolerances and thermal expansion, not dynamic motion

↻ Direction of shaft rotation for output signals as per the interface description

	Absolute	
	ECN 1123 – Singleturn	EQN 1135 – Multiturn
Safety-related data	Applicable as single-encoder system in the control loop for applications of the control category <ul style="list-style-type: none"> • SIL2 (Safety Integrity Level) according to DIN EN IEC 61 508 • PL d (Performance Level) according to DIN EN ISO 13849 • Category 3 according to EN 954-1 Safe in the singleturn range	
PFH	$\leq 1 \times 10^{-8}$ (probability of failure per hour)	
Angular error of the safe position	$\leq \pm 0.7^\circ$ (9 bits)	
Absolute position values	EnDat 2.2	
Ordering designation	EnDat 22	
Position values per rev	8388608 (23 bits)	
Revolutions	–	4096 (12 bits)
Elec. permissible speed	$\leq 12000 \text{ min}^{-1}$ (for continuous position value)	
Calculation time t_{cal}	$\leq 5 \mu\text{s}$	
System accuracy	$\pm 60''$	
Power supply	3.6 to 14 V–	
Current consumption ¹⁾	$\leq 180 \text{ mA}$ (with load)	$\leq 200 \text{ mA}$ (with load)
Electrical connection Via PCB connector	15-pin (with connection for temperature sensor ²⁾ ; optimized for KTY 84-130)	
Cable length	$\leq 100 \text{ m}$	
Shaft	Blind hollow shaft $\varnothing 6 \text{ mm}$	
Mech. permissible speed n	$\leq 12000 \text{ min}^{-1}$	
Starting torque at 20 °C	$\leq 0.001 \text{ Nm}$	$\leq 0.002 \text{ Nm}$
Moment of inertia of rotor	$0.4 \cdot 10^{-6} \text{ kgm}^2$	
Angular acceleration of rotor	$\leq 1 \times 10^5 \text{ rad/s}^2$	
Natural frequency of the stator coupling	$\geq 1800 \text{ Hz}$	
Permissible axial motion of measured shaft	$\pm 0.5 \text{ mm}$ (see mating dimensions $\text{\textcircled{B}}$)	
Vibration 10 to 2000 Hz ³⁾ shock 6 ms	$\leq 200 \text{ m/s}^2$ (EN 60068-2-6) $\leq 1000 \text{ m/s}^2 / \leq 2000 \text{ m/s}^2$ (EN 60068-2-27)	
Max. operating temperature	115 °C	
Min. operating temperature	–40 °C	
Relative humidity	$\leq 75 \%$; temporary $\leq 95 \%$ (condensation not permissible)	
Protection EN 60529	IP 40 when mounted	
Weight (approx.)	0.1 kg	

¹⁾ Depends on the power supply; see *General Electrical Information*

²⁾ Only use sensors with double or reinforced insulation. Ensure that the lines are routed inside the motor housing.

³⁾ 10 to 55 Hz constant over distance 4.9 mm peak to peak

General Electrical Information

Power supply

The encoders require a **stabilized dc voltage U_p** as power supply. The required power supply and the current consumption are given in the respective specifications state. The values apply as measured at the encoder, i.e., without cable influences.

Connect HEIDENHAIN position encoders only to subsequent electronics whose power supply is generated through double or strengthened insulation against line voltage circuits. Also see **IEC 364-4-41: 1992**, modified Chapter 411 regarding "protection against both direct and indirect touch" (PELV or SELV). If position encoders or electronics are used in safety-related applications, they must be operated with protective extra-low voltage (PELV) and provided with overcurrent protection or, if required, with overvoltage protection.

Isolation

The encoder housings are isolated against internal circuits.

Rated surge voltage: 500 V (preferred value as per VDE 0110 Part 1, overvoltage category II, contamination level 2)

Current consumption

For encoders with extended voltage range (3.6 V to 14 V) the current consumption depends on the actual power supply. The maximum possible value is listed in the specifications. This diagram shows the current consumption for the respective power supply values.

Cable

HEIDENHAIN cables are mandatory for use in safety-related applications.

Lengths

The cable lengths listed in the *Specifications* apply only for HEIDENHAIN cables and the recommended input circuitry of the subsequent electronics.

Durability

All encoders have polyurethane (PUR) cables. PUR cables are resistant to oil, hydrolysis and microbes in accordance with **VDE 0472**. They are free of PVC and silicone and comply with UL safety directives. The **UL certification** AWM STY LE 20963 80 °C 30 V E63216 is documented on the cable.

Temperature range

HEIDENHAIN cables can be used for
fixed cable -40 °C to 80 °C
frequent flexing -10 °C to 85 °C

Cables with limited resistance to hydrolysis and microbes are rated for up to 100 °C. If necessary, please ask for assistance from HEIDENHAIN Traunreut.

Bend radius

The permissible bend radii R depend on the cable diameter and the configuration:

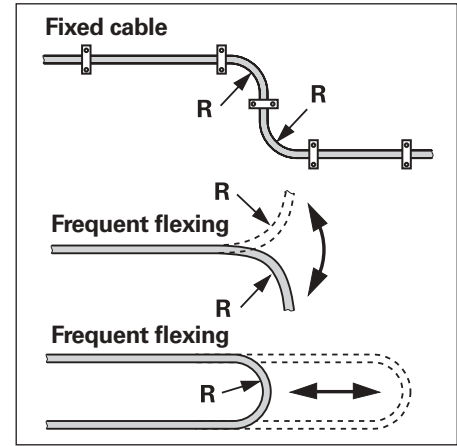

HEIDENHAIN cables	Rigid configuration	Frequent flexing
Ø 4.5 mm	$R \geq 10 \text{ mm}$	$R \geq 50 \text{ mm}$
Ø 6 mm	$R \geq 20 \text{ mm}$	$R \geq 75 \text{ mm}$

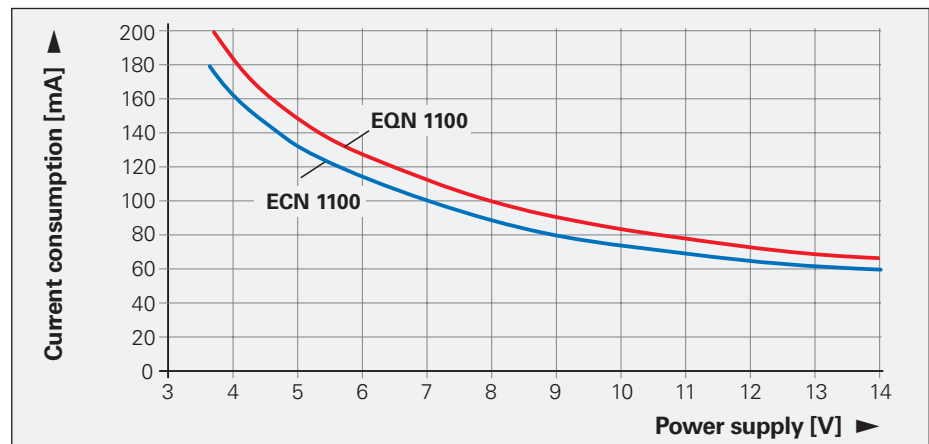

Maximum current consumption with connected subsequent electronics depending on the supply voltage

Noise-Free Signal Transmission

Electromagnetic compatibility/ CE compliance-

When properly installed, and when HEIDENHAIN connecting cables and cable assemblies are used, HEIDENHAIN encoders fulfill the requirements for electromagnetic compatibility according to 89/336/EEC with respect to the generic standards for:

- **Noise immunity EN 61000-6-2:**

Specifically:

– ESD	EN 61 000-4-2
– Electromagnetic fields	EN 61 000-4-3
– Burst	EN 61 000-4-4
– Surge	EN 61 000-4-5
– Conducted disturbances	EN 61 000-4-6
– Power frequency magnetic fields	EN 61 000-4-8
– Pulse magnetic fields	EN 61 000-4-9

- **Interference EN 61000-6-4:**

Specifically:

– For industrial, scientific and medical (ISM) equipment	EN 55011
– For information technology equipment	EN 55022

Transmission of measuring signals— electrical noise immunity

Noise voltages arise mainly through capacitive or inductive transfer. Electrical noise can be introduced into the system over signal lines and input or output terminals.

Possible sources of noise are:

- Strong magnetic fields from transformers, brakes and electric motors
- Relays, contactors and solenoid valves
- High-frequency equipment, pulse devices, and stray magnetic fields from switch-mode power supplies
- AC power lines and supply lines to the above devices

Protection against electrical noise

The following measures must be taken to ensure disturbance-free operation:

- Use only original HEIDENHAIN cables.
- Use connectors or terminal boxes with metal housings. Do not conduct any extraneous signals.
- Connect the housings of the encoder, connector, terminal box and evaluation electronics through the shield of the cable. Connect the shielding in the area of the cable outlets to be as induction-free as possible (short, full-surface contact).
- Connect the entire shielding system with the protective ground.
- Prevent contact of loose connector housings with other metal surfaces.
- The cable shielding has the function of an equipotential bonding conductor. If compensating currents are to be expected within the entire system, a separate equipotential bonding conductor must be provided. Also see **EN 50 178/4.98** Chapter 5.2.9.5 regarding "protective connection lines with small cross section."

- Do not lay signal cables in the direct vicinity of interference sources (inductive consumers such as contacts, motors, frequency inverters, solenoids, etc.).
- Sufficient decoupling from interference-signal-conducting cables can usually be achieved by an air clearance of 100 mm or, when cables are in metal ducts, by a grounded partition.
- A minimum spacing of 200 mm to inductors in switch-mode power supplies is required. See also **EN 50 178/4.98** Chapter 5.3.1.1, regarding cables and lines, as well as **EN 50 174-2/09.01**, Chapter 6.7, regarding grounding and potential compensation.
- When using **rotary encoders in electromagnetic fields** greater than 30 mT, HEIDENHAIN recommends consulting with the main facility in Traunreut.

Both the cable shielding and the metal housings of encoders and subsequent electronics have a shielding function. The housings must have the **same potential** and be connected to the main signal ground over the machine chassis or by means of a separate potential compensating line. Potential compensating lines should have a minimum cross section of 6 mm² (Cu).

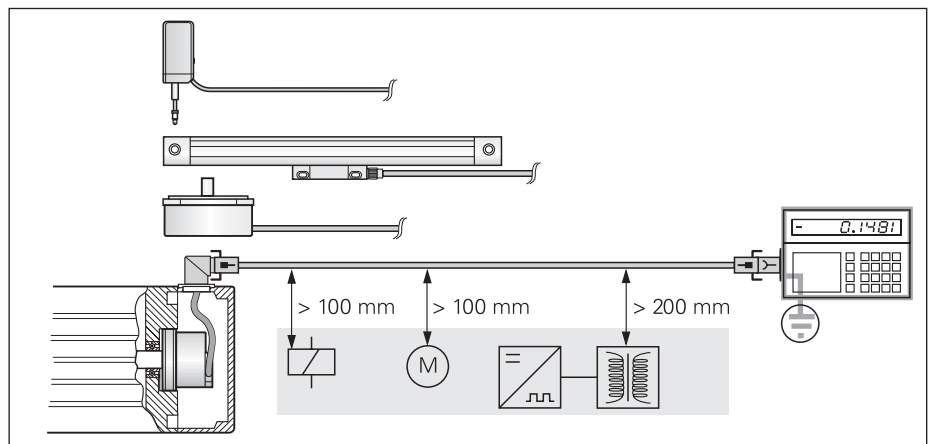





Minimum distance from sources of interference

Electrical Connection



Cable with M12 connecting element, 8-pin

EnDat 22 without
Incremental signals

Encoder cable inside the motor housing Cable diameter 4.5 mm 16xAWG30/7		
Complete with 15-pin PCB connector and 8-pin M12 angle socket		606080-xx
PUR connecting cables 8-pin: [(4 × 0.14 mm ²) + (4 × 0.34 mm ²)] Ø 6 mm		
Complete with connector (female) and coupling (male)		368330-xx
Complete with connector (female) and D-sub connector (female) for IK 220		533627-xx
Complete with connector (female) and D-sub connector (male) for IK 115/IK 215		524599-xx
With one connector (female)		559346-xx ¹⁾

¹⁾ Connecting element must be suitable for 8 MHz signal transmission.

Pin layout

8-pin M12 coupling								
								
	Power supply				Absolute position values			
	2	8	1	5	3	4	7	6
	U_p ¹⁾	U_p	0V ¹⁾	0V	DATA	DATA	CLOCK	CLOCK
	Blue	Brown/Green	White	White/Green	Gray	Pink	Violet	Yellow

Shield on housing; **U_p** = power supply voltage

Vacant pins or wires must not be used!

¹⁾ For parallel supply lines

HEIDENHAIN cables, complete with connectors, are required for use in safety-related applications!

HEIDENHAIN

DR. JOHANNES HEIDENHAIN GmbH

Dr.-Johannes-Heidenhain-Straße 5

83301 Traunreut, Germany

☎ +49 (8669) 31-0

FAX +49 (8669) 50 61

E-Mail: info@heidenhain.de

www.heidenhain.de

Related documents

- Mounting Instructions:
ECN 1123, EQN 1135 642 066-xx
- Technical Information: *Safety-Related Position Encoders* 596 632-xx
- Interface Description *EnDat 297 403-xx*
- System specification: *Specification of the E/E/PES safety requirements for the EnDat master and measures for the safe control* 533 095-xx

